

Installation and Operation of SV30 Hybrid with 100 L Cylinder

**Solar Heating System for Fresh Air and Domestic Hot Water
with 12V Solar Cell Operated Pump and Fan**

See separate instructions for wall or roof mounting



SolarVenti

..... at your sunny service

1.0 Contents	3
1.1 The SV30 Hybrid Principle	4
1.2 An SV30 Hybrid solar collector on the roof	5
2.0 Planning the position of the SV30 Hybrid	6
2.1 How to position the SV30 Hybrid solar collector	6
2.2 How to position the hot water cylinder	6
2.3 How to position the expansion tank	7
2.4 Concerning piping location	7
3.0 Installation Instructions	8
3.1 Installing the SV30 Hybrid Solar Collector	8
3.1.1 Drilling holes in the roof	8
3.2 Piping and insulation	8
3.3 Roof lead-in	8
3.4 Installing the expansion tank	9
3.5 Installing the hot water cylinder.....	10
3.5.1 Fittings on the hot water cylinder	10
3.5.2 Mounting the fittings on the hot water cylinder.....	11
3.5.3 Connecting the domestic water	12
4.0 The SV30 Hybrid in operation	12
4.1 Starting up a new installation	13
4.2 Testing pump and circulation	13
4.3 Adding anti-freeze (for locations in risk of frost)	13
4.4 Re-starting your SV30 Hybrid	13
5.0 Venting the installation	14
6.0 Adjustment	14
6.1 Adjusting the flow in the solar collector	14
7.0 Performance	15
7.1 Automatic pump and fan performance	15
8.0 Maintenance	15
9.0 Warranty and insurance	15
9.1 Warranty	15
9.2 Insurance	15
Attachments:	
3 m² SV30 Hybrid Solar Collector	16
Circuit diagram with regulator and room thermostat	17

1.0 Contents

This manual describes the partial do-it-yourself installation, starting and operation of an SV30 Hybrid which includes an SV30 Hybrid solar collector with PP absorber, a 100 litres hot water cylinder, an expansion tank and solar cells for the operation of fan and pump.

The air based part of the system will blow the warm air from the collector into the house by means of a solar cell operated fan.

The fluid based part of the system will heat up the domestic water by pumping the liquid in the PP tubes of the collector through the heat exchanger of a 100 L hot water cylinder using a solar cell operated pump.

To ensure the optimal performance of this low-tech system this manual offers advice on the positioning of the various components of the SV30 Hybrid. It will also deal with the initial adjustment, the operation and maintenance, and it will give you additional technical information concerning specific components in the system.

Separate instructions are provided for roof or wall mounting the collector. When mounting on roof, however, it is important to distinguish between the two types available:

- Type 1 for solid roofs with profiled sheeting (for instance fibre cement)
- Type 2 for steel plate or asphalt roofing

Upon receipt of your SV30 Hybrid please check that you have received all components in a good condition.

Please note that **a certified plumber** may be required to perform and/or check certain parts of the installation.

The electrical connection is only 12V (not 230/240V) and therefore constitutes no danger.

Caution: It is important to note that although the system is self-circulating, temperatures of about 100° C may be generated in the upper part of the solar collector in case of pump or fan failure.

We urge you to read the instructions thoroughly before you go ahead with the installation. It is important to plan the optimal position of the system and to know how to progress in this partial do-it-yourself working process.

Enjoy yourself!

1.1 The SV30 H-Plus Principle

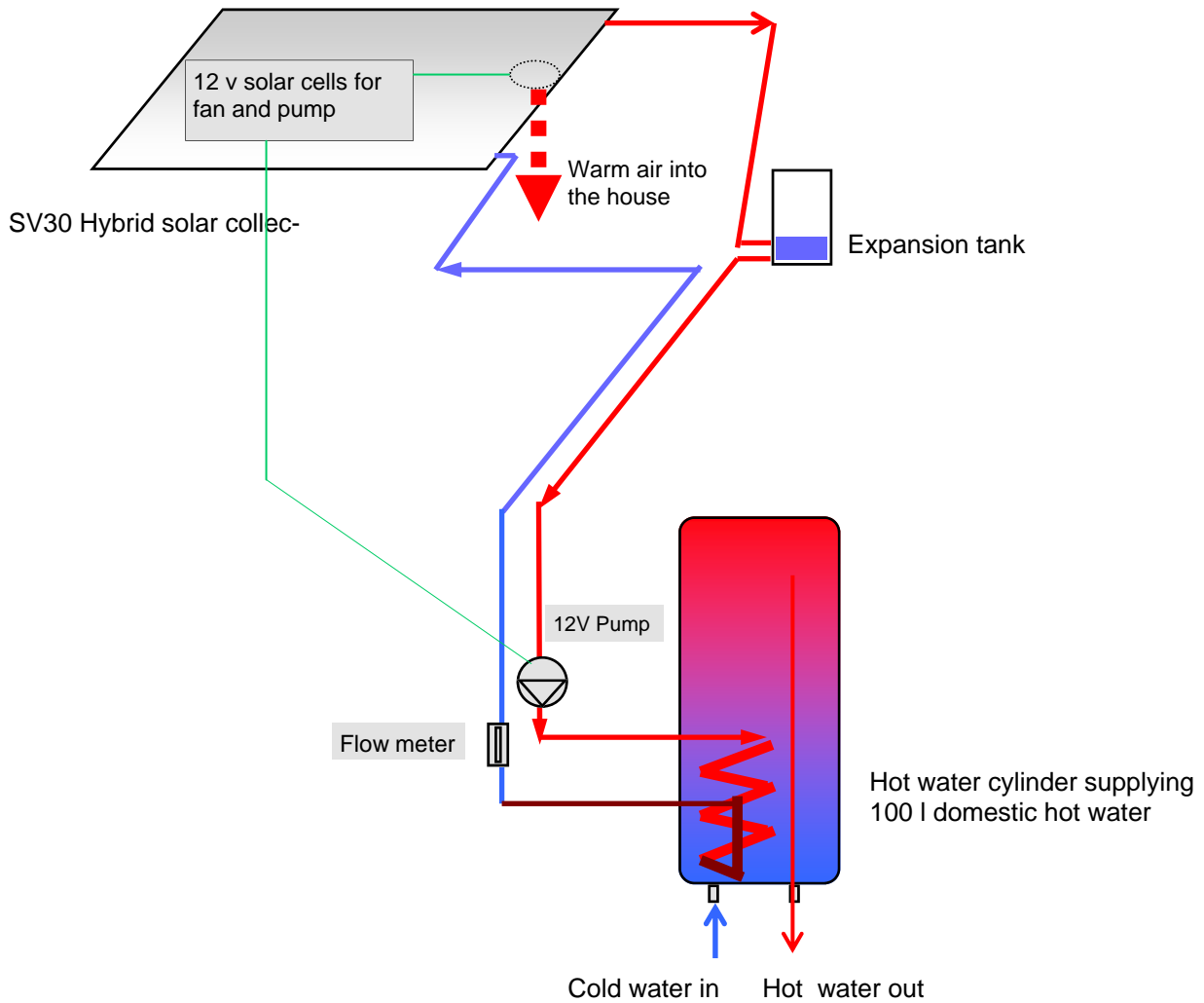

The most important components of the SV30 Hybrid are:

SV30 Hybrid solar collector with solar cells and fan - expansion tank - cylinder - pump

The SV30 Hybrid produces:-

- **Fresh and warm air**, which keeps your house pleasantly dry and moderately heated most of the year.
- **Domestic hot water**, often as a supplement to a pre-installed electric water heater.

1.2 A roof mounted SV30 Hybrid solar collector



Please note that the SV30 Hybrid solar collector is located with the long dimension parallel to the horizontal

Inlet and outlet are always placed on the **same** side of the collector. By rotating the collector 180° you may choose between the right and the left side.

2.0 Planning the position of the SV30 Hybrid

This low-tech plant is designed to let the forces of nature work for you to the maximum practical extent. This will benefit the environment and reduce your costs of living for many years ahead.

In order to ensure the optimal performance of your SV30 Hybrid it is important to consider:-

- The position of the solar collector in relation to the sun and to the rooms of the house
- The position of the other components in relation to the collector and the construction of the house
- The interaction between the various parts of the system

The instructions given below will take you through this process step by step

2.1 How to position the SV30 Hybrid solar collector

- **In relation to the sun:**
When planning the position of the collector on roof or wall you will have to consider how the maximum amount of sunlight can be received. If possible the collector should be directed at solar noon. However, a deviation of up to 45° is acceptable. The inclination from horizontal should range between 60° and 90°. App. 65° is optimal.
- **In relation to the rooms of the house:**
Please note that the incoming fresh, warm air can only be achieved with the inlet vent in the immediate vicinity of the collector, so it is important to place the collector above (or against) a room well suited for this purpose.

Please read separate instructions for further details.

2.2 How to position the hot water cylinder

The hot water cylinder should be installed so that the horizontal distance to the SV30 Hybrid solar collector is as short as possible.

The hot water cylinder can often be located in a scullery or a furnace room or wherever practical. However, there must be access to both **power and the domestic water supply**.

The location should **include a drain** as water will occasionally drip from a safety valve.

An open space of 50 cm minimum should be maintained in front of the cylinder for service access. If possible, ensure that additional space is reserved for service of the equipment below the bottom of the cylinder too. In case of restricted space, a safety valve may be placed on the side of the cylinder.

Space must be reserved for piping to and from the SV30 Hybrid solar collector. Lead-in is often made through ceiling and floor. Please note that all piping to and from the collector must be insulated.

If the hot water cylinder is located in a loft, a frost-proof outlet must be established. Use anti-freeze to avoid potential frost in the pipes. If an electric water heater is used for frost protection a thermostat should be installed to prevent it from working when the room temperature exceeds +5°C.

Take care not to impair or damage the fabric of the building when installing the hot water cylinder.

2.3 How to position the expansion tank

The expansion tank should be placed as high up as possible, preferably above the hot water cylinder.

The difference in the levels between the bottom of the expansion tank and the top of the SV30 Hybrid solar collector should be as small as possible.

The expansion tank must be placed in a vertical position.

The expansion tank must be installed in a stable position so that it can carry 10 l (max 15 kg). It may for instance be placed on a plate in the loft between two rafters.

If the distance between the hot water cylinder and the solar collector exceeds 15 m, the expansion tank must be placed in the loft above the cylinder.

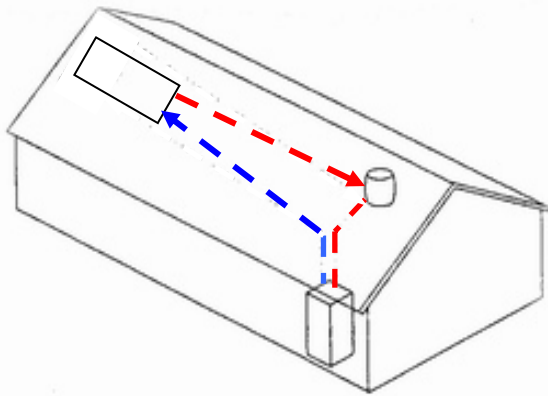

Possible position

For distances exceeding 15 m, place the expansion tank in the loft above the cylinder
Use 16 mm PP smooth tube for distances exceeding 12 m between the solar collector and the cylinder

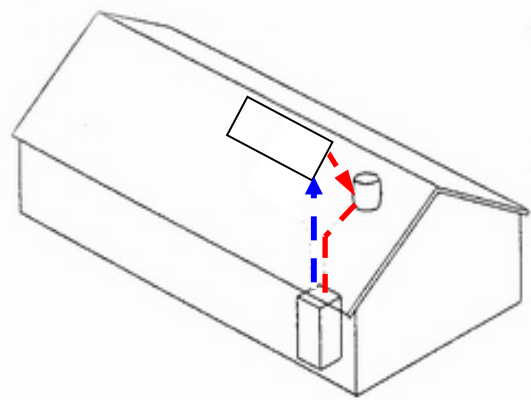

Optimal position

Short distance between the expansion tank, the solar collector and the cylinder.
Use 16 mm rib tube.

2.4 Concerning piping location

Horizontal or ascending piping from the hot water cylinder to the SV30 Hybrid solar collector is optimal. Otherwise you may have problems starting the installation.

It is possible to place the expansion tank below collector level. However, the difference in height between the top of the collector and the bottom of the expansion tank should be a maximum of 2 m.

To reduce piping resistance, for distances exceeding 12 m between the solar collector and the hot water cylinder we recommend the use of 16 mm PP smooth tube.

Care should be taken to avoid bends (no air pockets!) and to establish either a horizontal or a falling piping run between the expansion tank and the cylinder as the pump pressure is released behind the expansion tank.

3.0 Installation Instructions

3.1 Installing the SV30 Hybrid Solar Collector

Please follow the general installation instructions for the SV30. These instructions come in three versions which are all included:

SV30 on wall

Sv30 on roof type 1 (fibre cement, tile etc. Type of roof with overlapping plates or similar)

SV30 on roof type 2 (asphalt or steel plates. Type of roof with no overlapping)

3.1.1 Drilling holes in the roof

One hole $\varnothing = 20$ mm is made for the cold piping to the SV30 Hybrid solar collector. This hole is made next to the lowest pipe outlet on the collector. (For type 1, take care always to drill in crests!)

A second hole $\varnothing = 20$ mm for the hot piping from the collector is made next to the first. (See page 7)

Before drilling make sure that the position is correct.

A rubber lead-in will secure the watertight lead-in of the 16 mm tube through the roof plate.

3.2 Piping and Insulation

- 1) 16 mm rib tube (or smooth tube for distances over 12 m) is insulated and fixed. Fasten the tubes with strips or wire to laths at short intervals to avoid bends.
- 2) Intense heating may result in linear expansion especially in rib tubes, but smooth tubes will also expand to some degree. Normally, this causes no problems. However, care should be taken to prevent the pipes from rubbing on sharp edges or the like.

Long piping arrangement on the roof

If it is necessary to lay tubes outside on a roof etc., the insulation must be protected by a wind and weather proof tube. This kind of tube comes in 25, 39, 48 and 63 mm \varnothing and can be pulled over the insulation.

Note: The wire on the roof is secured from birds by pulling it through the rib tube

3.3 Roof lead-in

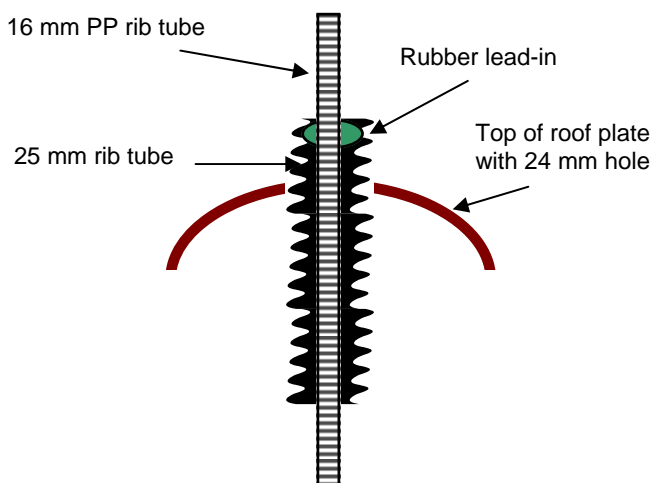

Roof lead-in can be performed in several ways

A piece of 25 mm rib tube is pulled tightly through a hole drilled with a 24 mm drill. Subsequently, use silicone to seal the hole.

The rubber lead-in ring is placed on top of the rib tube after which the 16 mm rib pipe can be drawn through.

Insulate everything with black insulation material which will also carry off water from the lead-in. Alternatively, a rubber lead-in may be placed directly in a 20 mm hole on the roof ridge and the rib tube pulled through.

3.4 Installing the expansion tank

The expansion tank is located on the hot piping line from the SV30 Hybrid solar collector to absorb any expanding fluids.

It is designed to absorb all fluids in the system, for instance in case of boiling if the power source is disconnected.

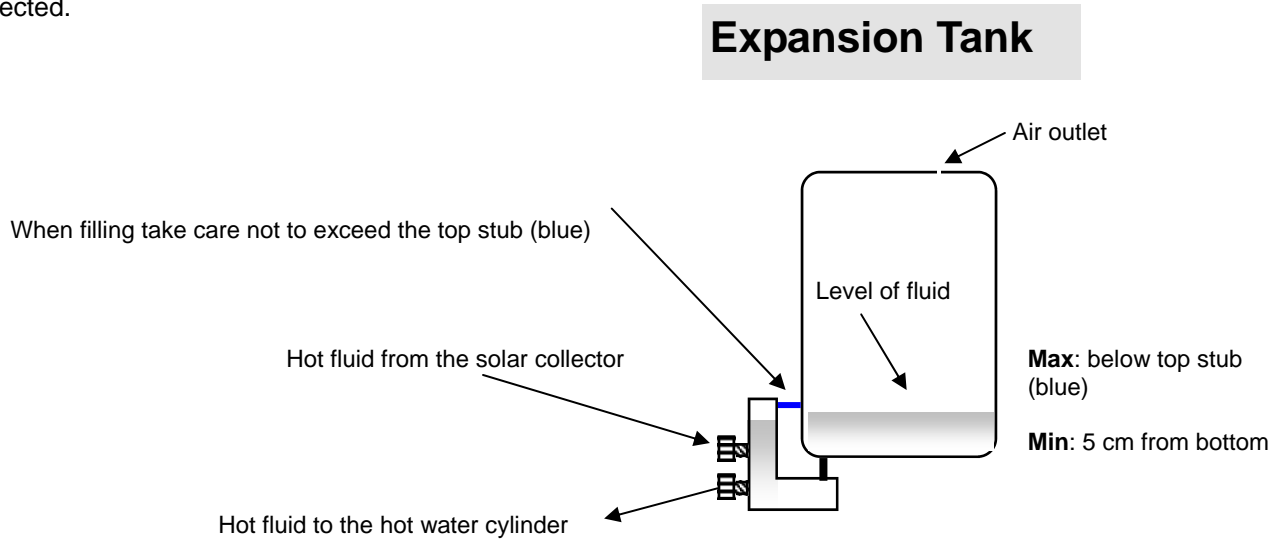

Normally, there is little or no risk of overflowing, but it may occur if the recommended level of fluid is exceeded.

In order to avoid any damage you may additionally fit the expansion tank with an overflow pipe

Notice!

If the expansion tank is filled above the recommended level a loss of heat may incur as a result of the self circulation, and the space reserved for fluid expansion will be reduced

3.5 Installing the hot water cylinder

Important: The base or wall fittings must be dimensioned to carry a full cylinder (app 170 kg)

3.5.1 Fittings on the hot water cylinder

The hot water cylinder is supplied with a range of connecting parts and a pump. Please follow the directions for fitting these items. More details are on the next pages.

Important: Note the marking for flow direction on the pump and be sure to fit it in a vertical position so that it can self ventilate!

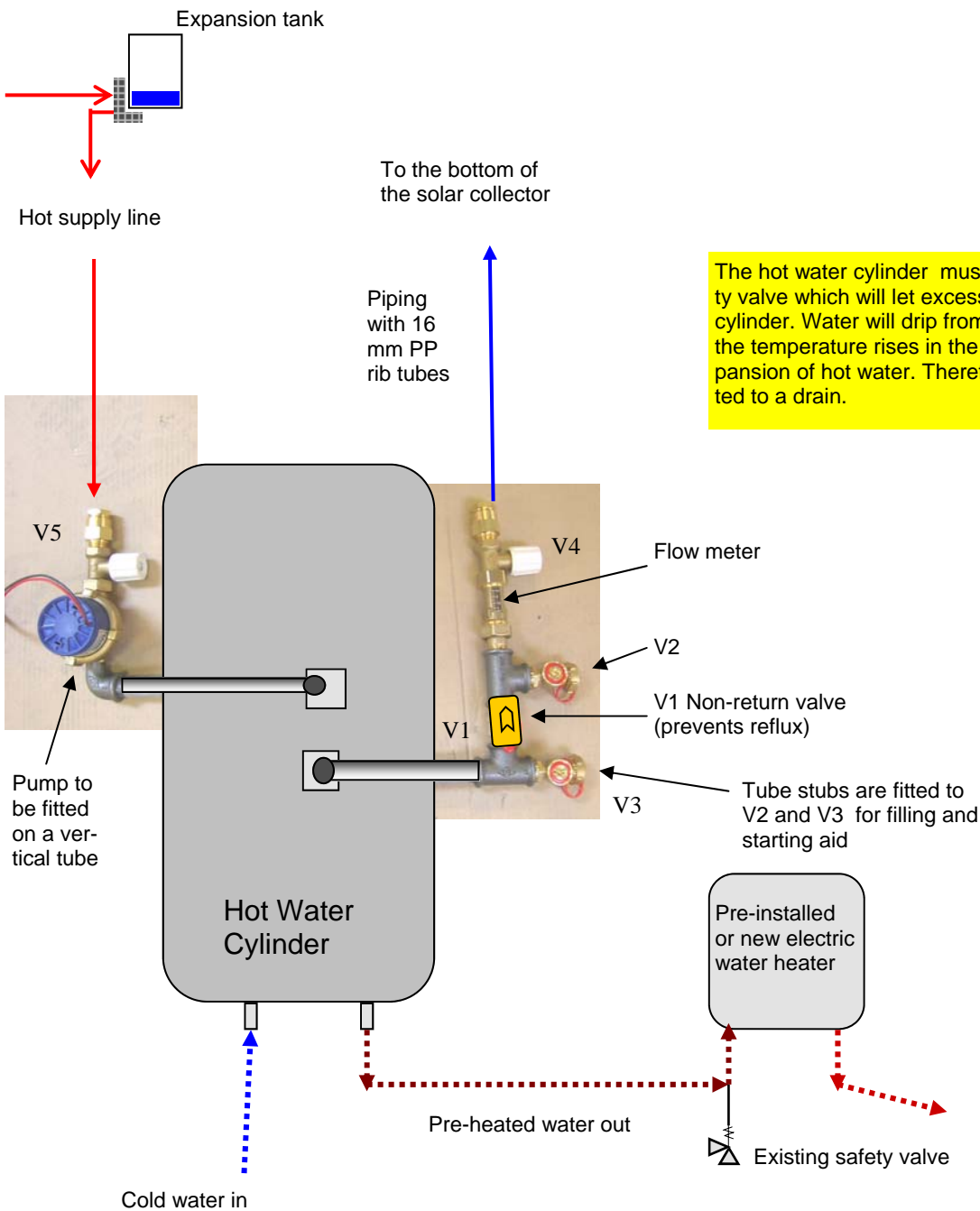

The hot water cylinder must be connected to a safety valve which will let excess pressure out of the cylinder. Water will drip from the safety valve when the temperature rises in the cylinder due to the expansion of hot water. Therefore, it must be connected to a drain.

3.5.2 Mounting the fittings on the hot water cylinder

Piping arrangements may differ slightly from the example shown on the pictures.

When the hot water cylinder has been installed and is leveled, the tubes connecting the cylinder to the H-Plus solar collector and the expansion tank can be fixed.



Pre-heated water out Cold water in

Domestic water supply line may require safety fittings. Please check the instructions given by the hot water cylinder manufacturer.
This installation must be performed by a certified plumber.

Important:
 Take care to fit the pump correctly!

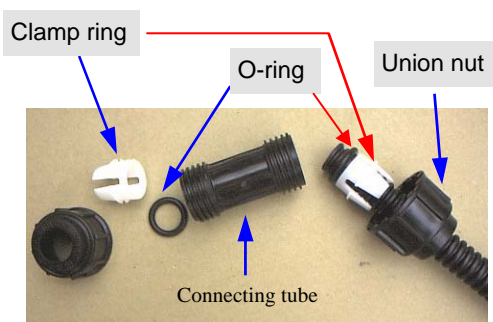

ASTORE plastic fittings:

Start by fitting the O-ring, the clamp ring and union nut to the tube. Subsequently, fit these items into the connecting tube.

Do NOT use tools to tighten the union nut, - only manual power!

EV brass collector: use the same principle as for the plastic collector. Take care that the clamp ring is straight and pressing against the O-ring

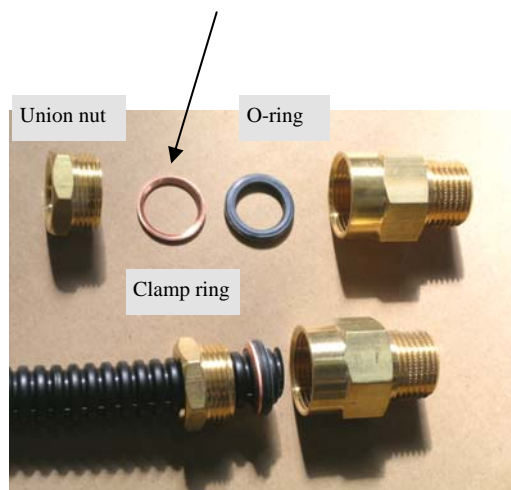

3.5.3 Connecting the domestic water

IMPORTANT NOTICE!
It is imperative that this installation is performed by a certified plumber

Hot water cylinder with 100 L domestic water

- The cold water inlet is connected to the 3/4" stub for cold water in (pos. c).
- The hot water outlet is connected to the 3/4" stub for hot water out (pos. b).
- Overflow from the safety valve (pos. d) is led to the drain
- Hot water cylinder and piping are flushed and the cylinder is filled with water.
- The cylinder is vented through the nearest hot water tap.
- Allow the tap to stay open until all the air is out.
- Test cylinder and all fittings for leakages

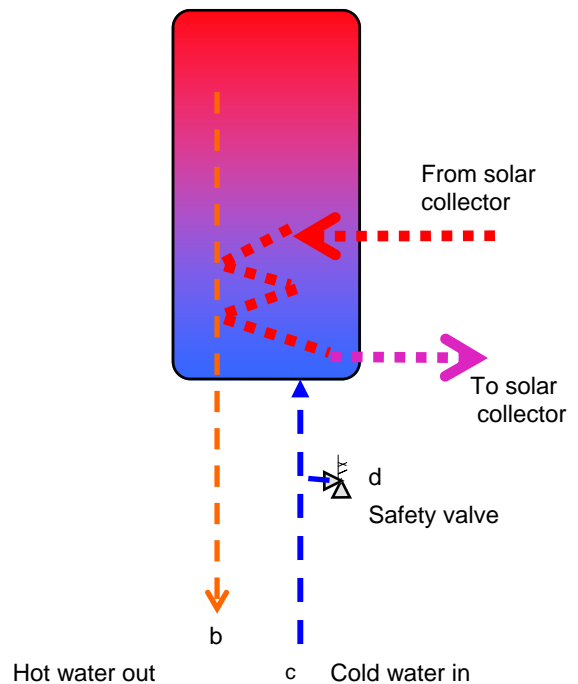

4.0 The SV30 Hybrid in operation

Now it is time to connect the hot water cylinder to the SV30 Hybrid solar collector and the expansion tank. There are some important steps to follow. First of all a specific quantity of water must be supplied.

Quantity of liquid:

SV30 Hybrid approx.	: 8,0 L
Heat exchanger in cylinder	: 2,0 L
Piping: 2 x 8 m	: 2,0 L
Expansion tank app.	: 2,0 L (5 cm at the bottom)

Totalling approx. : 15 L

Now you are ready to fill the solar collector circuit with water using the steps stated on the next page.

4.1 Starting up a new installation:

(See illustration on page 10 for references)

1. Check that all connections are joined correctly
2. Ensure that the pump (12V) is disconnected
3. Fully open valves V4 and V5
4. Water (without anti-freeze) is filled via valve V2 until water reaches the expansion tank
5. Shut valve V2 and add water to via valve V3 until the water reaches the expansion tank
6. Check if there are any leakages

4.2 Testing pump and circulation

1. Connect the pump (take care to use correct polarity!)
2. If the sun does not shine a 12V battery may be used to run the pump
3. Check the flow gauge when the pump runs. Output should be at least 1 L/min
4. If the flow is below this minimum there is probably air in the system.
5. A power drill pump may be inserted between valves V3 and V2 (V1 ensures correct flow direction) to force circulation.
6. The pump sucks from valve V3 and blows into valve V2
7. Run for some minutes until there is no evidence of air bubbling in the expansion tank.
8. Test the system again with the ordinary pump
9. Add water if the liquid level in the expansion tank is below minimum
10. If there is flow in the system proceed to 4.3 Otherwise go back to step 5

Note: If a battery is used as starting aid, the regulator should be bypassed and a 12V battery connected direct to the pump.

4.3 Adding anti-freeze (for locations with risk of frost)

1. 5 L of anti-freeze is pumped in at valve V2
2. An equivalent volume is let out at valve V3
3. Watch the liquid level in the expansion tank
4. If the level is below minimum add water. When doing this turn off the pump to avoid any sucking in of additional air.
5. Do not fill the expansion tank to overflowing.

4.4 Re-starting your SV30 Hybrid

If you have turned off the fluid based part of your SV30 H-Plus for a period, it is necessary to re-start it.

Whilst the equipment is already filled with liquid, this will normally cause no problem.

Please follow the instructions below:

- Check the liquid level in the expansion tank. Add water if it is below minimum
- Connect the pump
- If there is sunlight, the circulation will normally start
- Otherwise follow the instructions given above in 4.2. step 5

5.0 Venting the equipment

Switch off the pump (disconnect on separate switch or draw out a wire)

The pipe union on the pump case should be turned counter-clockwise until air emerges. When the liquid starts flowing shut it again.

Switch on the pump and add liquid, if needed.

Note: It is not recommended that you switch off the pump when leaving the house, except for periods when only warm air input is needed.

6.0 Adjustment

The installation is now ready to work and must be adjusted for optimal performance.

Adjustment should be made as soon as possible and on a sunny day.

6.1 Adjustment of the flow in the solar collector

Make sure that the system is well vented for instance by running the pump for a couple of hours (see page 13). At low speed the flow should be minimum 1.0 L/min. The velocity varies according to the amount of sunlight.

The flow is indicated at the very back of the white marking. Normally, the flow is higher than 1.0 L/min which is perfectly OK.

Be sure to read the flow on the correct side of the felt pad!

If the initial flow is less than indicated above, check if the installation directions have been followed correctly.

Reduced flow may be caused by air in the system or lack of liquid. You may force the liquid to circulate by means of a power drill pump until the air is out. See page 13 for directions.

7.0 Performance

The installation has now been adjusted and is ready to perform. The SV30 Hybrid solar collector will heat the domestic water totally or partly. The electrical water heater will provide any after-heating necessary when the solar collector does not produce enough. To achieve power savings you should set the thermostat as low as possible.

7.1 Automatic pump and fan performance

Fan and pump will start and stop automatically depending on the level of sunlight. The fan is switched off when the room temperature exceeds the temperature set on the thermostat. This will result in more power for the pump which will automatically speed up. The pump can be provided with power direct from solar cells or connected to terminal 2 (brown wire) in the room thermostat so that it only runs when the fan stops. If you turn down the room thermostat the hot water production will increase as the pump will run more frequently when the fan is switched off. The plant will perform at its maximum total kW when both pump and fan run simultaneously.

8.0 Maintenance

Responsibility for the maintenance of the equipment rests with the user. An annual service check is recommended.

The SV30 Hybrid requires a minimum amount of maintenance, but in order to obtain the best economy of performance the following maintenance tasks should be carried out:

- Check the liquid level either direct on the expansion tank or by using the level control device.
- Check the concentration of anti-freeze. It must be sufficient to withstand minus 15°C.
- Check the function of the safety valve
- Check that the electronic anode of the cylinder is connected in accordance with the instructions

Lukewarm water and a soft brush may be used to wash the SV30 Hybrid solar collector.

9.0 Warranty and Insurance

9.1 Warranty

For warranty we refer to the sales and delivery conditions on the invoice.

9.2 Insurance

We recommend that you specify the SV30 Hybrid to your insurance company.

3 m² SV30 Hybrid Solar Collector

Note: Inlet and outlet are always placed on the same side of the SV30 Hybrid solar collector. The collector may be rotated 180°.

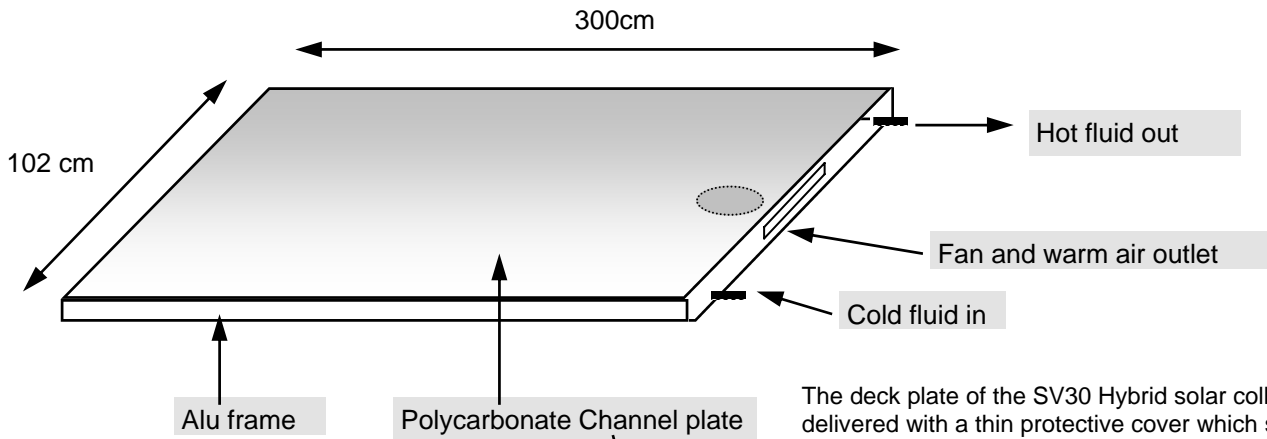

Cross section of the collector

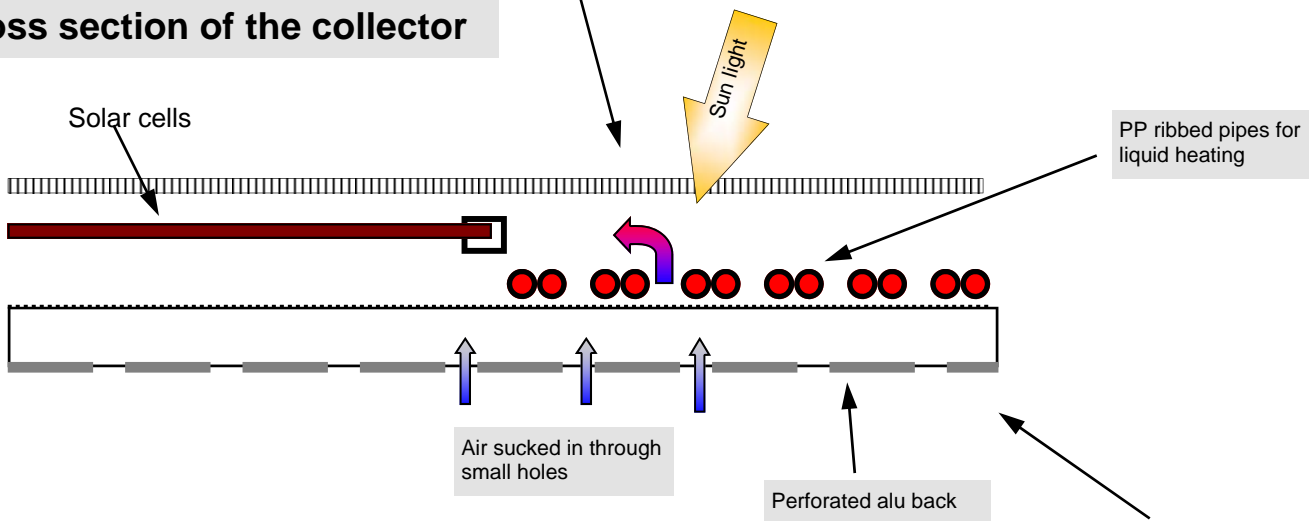

SV30 Hybrid Solar Collector 3,0 m²

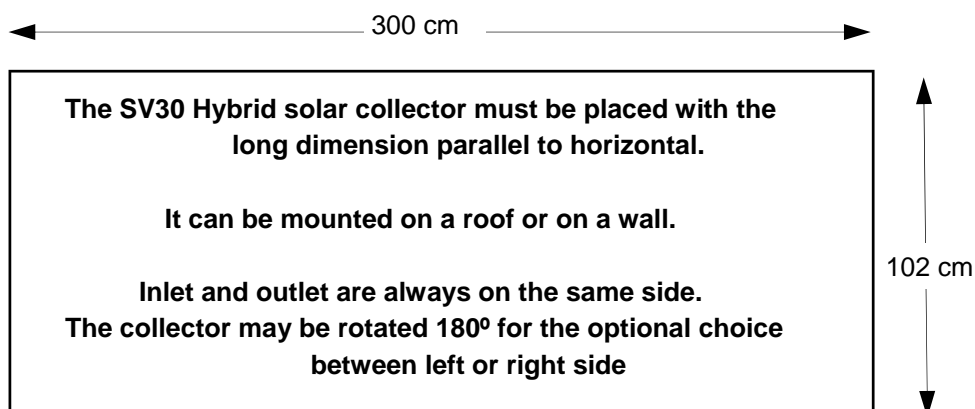

Circuit diagram with regulator and room thermostat: The wiring principle is shown here. It is a 12 Volt system, which means that touching the wires is harmless.

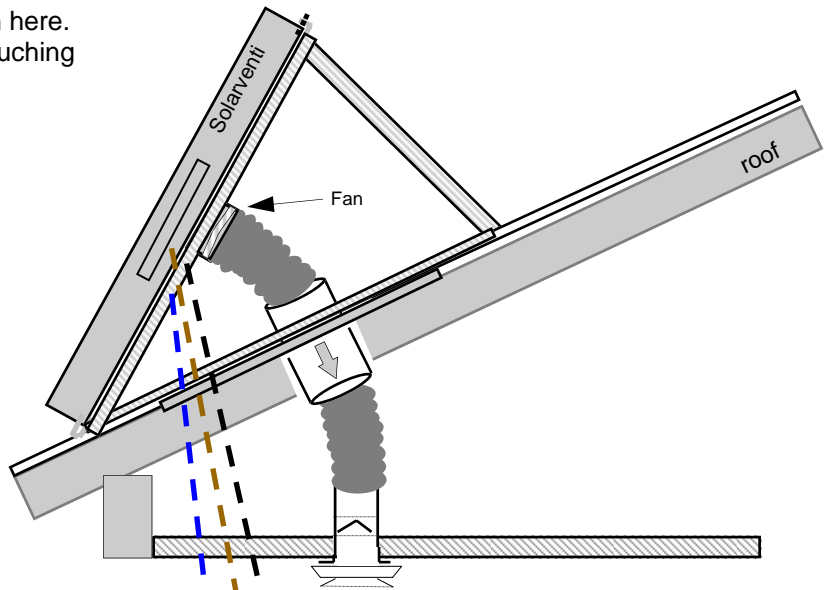

NOTE:
All 3 coloured wires are
assembled in one cable



Pump

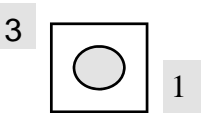

Room thermostat
(Schlüter S501):
Use clamps 1 and 3

The regulator is connected like this: The wires must be connected to the equivalent colours in the clamps.

The thermostat should be set on the highest temperature required, e.g. 25°C. If the room temperature exceeds 25°C, the fan is shut off.

NOTE:
Remember the system is only 12 Volt.
The wires must NOT be plugged to the normal electric supply mains!